

16K Memory for VZ-300 Computer

This 16K expansion can be built for considerably less than commercial versions. It comprises two 8K x 8 6264 CMOS static RAMs, a 74HC138 1-of-8 decoder and a 4008 4-bit adder.

IC3 and IC4 provide decoding of the A11 to A14 memory addresses to select IC1 and IC2 via the CS1-bar chip select inputs. The Y0 and Y1 outputs of IC3 ensure that when IC1 is selected IC2 is deselected and conversely, when IC2 is selected IC1 is deselected. A15 is used to select both IC1 and IC2 via the CS2 chip selects.

The MREQ-bar line is used to enable IC3 via the G2A-bar and G2B-bar inputs.

Read and Write (RD-bar and WR-bar) lines select the Write Enable-bar (WE-bar) and Output Enable-bar (OE-bar) of both IC1 and IC2.

Data lines D0 to D7 connect to the D0 to D7 lines of both IC1 and IC2. For the memory, A0 to A10 connect directly to the A0 to A10 lines of IC1 and IC2, while A11 and A12 connect via IC4.

Construction can be wire wrap or on Veroboard. A 44-way 2.54mm (0.1 inch) edge connector connects the memory expansion to the VZ-300 computer. The connections for this bus are shown.

M Kosovich,
Midland, WA.

\$20

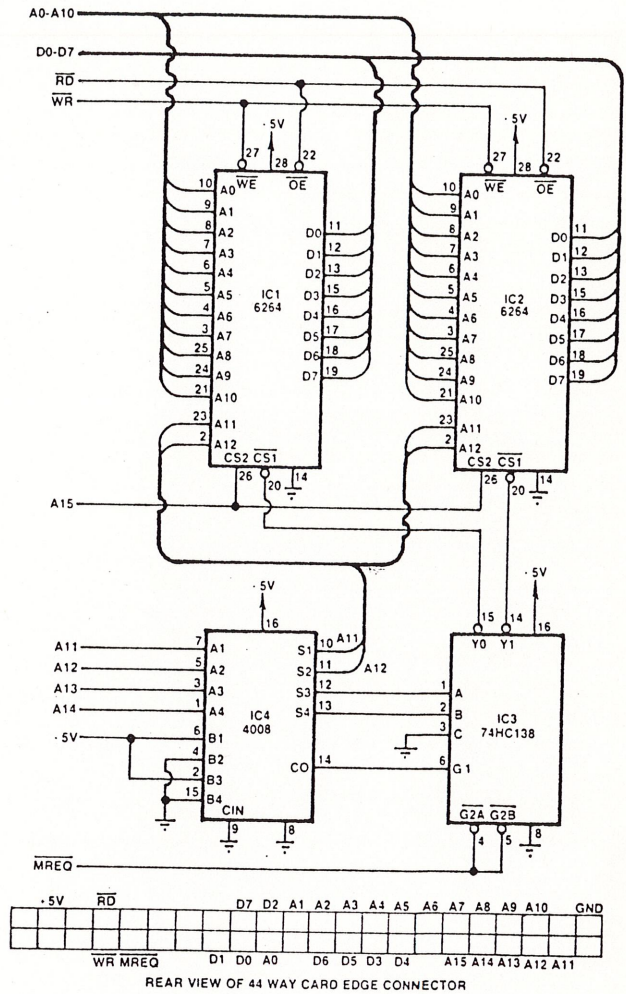

1 of 2

Notes & Errata

VZ-300 MEMORY EXPANSION (May 1987, CDI). Pins 2 and 4 of IC4 should be tied low and pins 6 and 15 tied high; not 4 and 15 low, and 2 and 6 high, as indicated. Connecting the circuit as shown may cause damage to either the static RAMs or the VZ-300.

VZ-300 expansion problem

From your "Circuit & Design Ideas" in the May issue I decided to make the "16K memory add-on for the VZ-300 computer". I thought it worth taking a chance on, and at the worst I might not be able to make it work. For it to kill my computer was more than I bargained for.

Your Notes & Errata in the August issue say this might happen if the circuit is constructed in the way shown. I have changed the internal RAM chips (4116) but the fault of garbage displayed did not change. I realise that it is not your usual policy but I would be very grateful if you could comment, from advice

you may have received, as to which chip or chips in the circuit are likely to have been damaged by the addition of this expansion. I hope you can help. (W.E.P., Christchurch NZ)

• We haven't had any further advice, but from your description that the unit now displays "garbage", it sounds as if either the 6847 video display controller chip (U15) or the 6116 video RAM (U7) may have been damaged somehow. Or perhaps the 74LS245 bus buffer U14, if there was a bus conflict. A remote possibility is that the Z80A CPU itself has been damaged. Sorry, but it's hard to offer more help than these suggestions.

VZ 300 expansion

I would like to respond to your reply to W.E.P. ("VZ-300 Expansion Problem", Information Centre, January 1988). I think you may be on the wrong track in your advice.

The "garbage on the display" is a familiar symptom to anyone who has tried to build "add-ons" to system-80s, TRS-80 Model Is etc. I believe the VZ series has similar ROMS.

The problem is that the screen is initially cleared by the startup routine software: there is no hardware clear-screen, and until the startup routine has run, the random contents of video RAM are displayed. Hence the "garbage on the screen".

I have not seen the original circuit, so I don't know exactly what has happened. Things to check are:

(1) Are the ROMS still properly seated in their sockets?

(2) Is there a possibility that there is an address conflict between the new RAM and either the video RAM or the ROM. Perhaps try starting the computer with all RAM removed?

(3) An easy thing to do is to short an address or data line to ground or 5V, or to one of the other bus lines.

In all these cases (and in all cases I have seen) there is usually no "damage" done, no blown chips or anything. You just have to find out why the CPU is not communicating correctly with the ROM & video RAM, remove the faulty connection, and everything works again. (R.L., Downer, ACT)

• Thanks for the helpful advice, R.L.

Circuit idea.

Some months ago I built a 16k memory expansion for my son's VZ-300, so far I have found it impossible to get to run properly. The fault seems to be incorrect memory addressing.

The circuit used came from your May 1987 magazine, in the Circuit and Design Ideas section.

Could you please tell me if any alterations or corrections were made to the circuit you published. My son is hoping to try and run Stan Blaster, which needs the extra memory, and at present is not pleased with a Dad who can't build things that work. (J.B., Nowra, NSW).

• Sorry J.B., but items published in the Circuit and Design Ideas section are presented "as is", directly as sent in by readers. As we note each month, we're not in a position to provide any further help with them.

2 of 2